



All Rights Reserved

Materials and specifications are subject to change without notice.
Featured machines in photos may include additional equipment.
See your XCMG dealer for available options.



WHEEL LOADER XC948



www.xcmg.com

XCMG Regional Departments:

Europe	(+86-516) 87739703 87739218 87739537	Africa	(+86-516) 87735009 87739222 87739283
West Asia & North Africa	(+86-516) 87739702 87739202 87739223	Central Asia	(+86-516) 87739236 87739239 87739538
Asia-Pacific	(+86-516) 87739128 87739500 87739529	America	(+86-516) 87739285 87739551 87739710

XUZHOU CONSTRUCTION MACHINERY GROUP IMP. & EXP. CO., LTD

Add: No.1, Tuolanshan Road, Xuzhou Economic Developing Zone, Jiangsu, China 221004

Fax: +86 (0) 516 8773 9228

E-mail: export@xcmg.com

XCMG MINING EQUIPMENT AUSTRALIA PTY LTD

Add: Level 10,185 Victoria Square Adelaide 5000 Australia.

Phone: +61 0411 591 394

E-mail: royrossini@xcmg.com

xcmgaustralia@xcmg.com

EURO III EMISSION



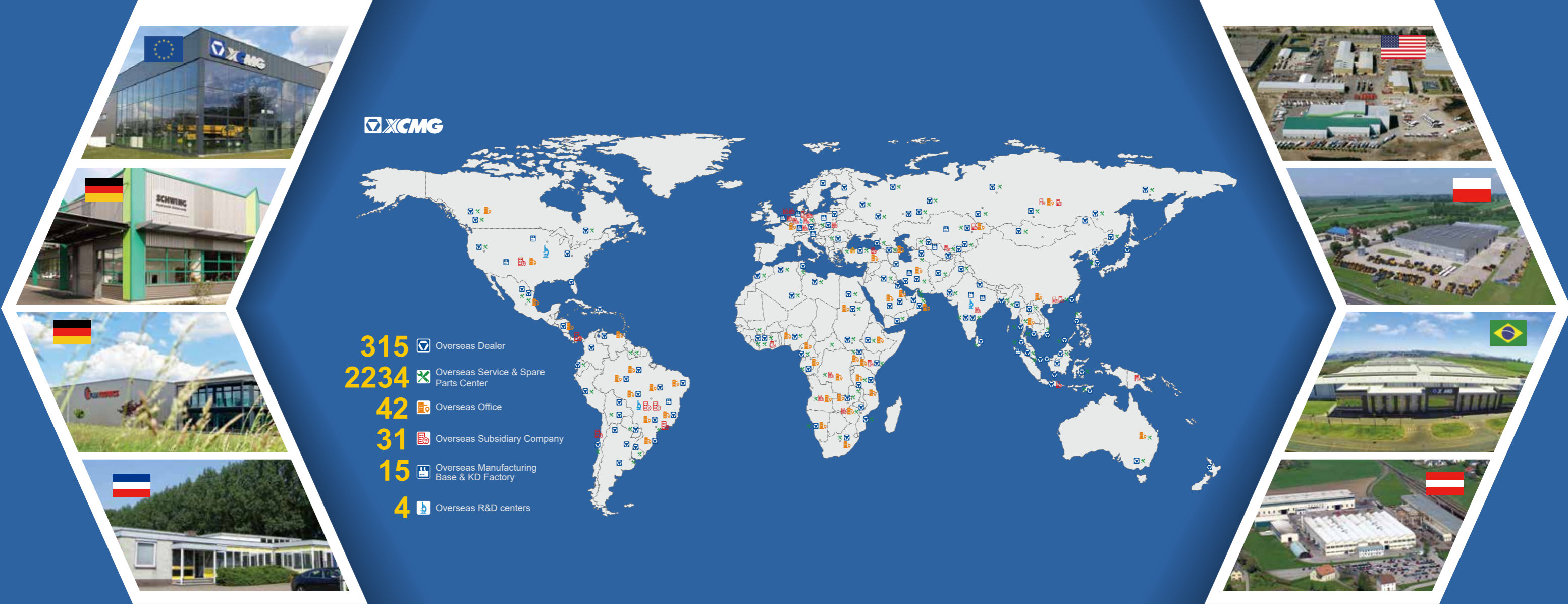

INTRODUCTION OF XCMG

Founded in 1943, XCMG is a multinational corporation with the most comprehensive range of competitive, influential products in the construction machinery industry. Our business covers eight key areas: construction machinery, heavy trucks, mining machinery, sanitation machinery, machinery components, construction, finance, and the ICT industry.

XCMG has established a global R&D network with a total of six centers in China, the US, Germany, Brazil and India, with China national technology center at its core. In addition to a number of manufacturing bases in China, the US, Germany, the Netherlands, Poland, Austria, Brazil, India, and Uzbekistan, we possess two complete machine brands (XCMG, Schwing), and several component brands including FT, AMCA. It is the strength of this global R&D network and manufacturing operations that has made XCMG the industry leading global construction equipment manufacturer that it is today.

For more than 30 years, XCMG has been sowing the seeds of overseas development as the No. 1 exporter in China's construction machinery industry. Today, we have 42 branches and offices, 315 distributors, 526 contractors in 188 countries and regions worldwide and are still growing rapidly.



PERFORMANCE AND FEATURES

High Reliability

Cummins QSB6.7 Engine, complying with Cummins QSB6.7 Engine providing power of complex working conditions and providing power of complex working conditions.

Automatic 4BP 190 torque converter, reduced shifting impact in travelling for various working conditions.

XCMG high performance wet axle, meeting high loaded working requirements.

Full hydraulic wet brake system of high reliability and maintenance free.

High Working Efficiency

Optimized linkage structure and hydraulic system with breakout force up to 130kN. JRB is the first choice for Quick Coupler in Australia. The coupler controls are conveniently located in the Cab. Bucket features discharge at high position, auto leveling and lifting limited technologies, reducing working cycle time.

Travel speed up to 36km/h with high transfer efficiency.

Extra heavy load frame structure design, FEA analysis on key structural to ensure strong structure and extended machine life.

Wear-resistance and impact-resistance high strength steel plate for bucket material.

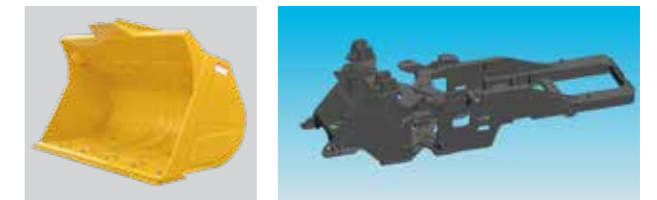
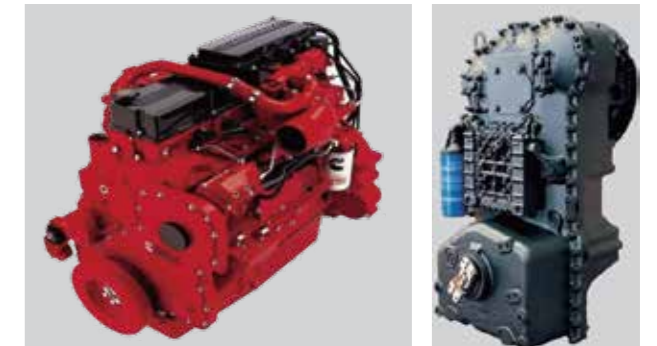

OVERVIEW

XC948 are developed by XCMG for Australia market integrating advanced design idea. XC948 meets EURO III emission engine, its overall design fits human aesthetic, the rear flip engine hood makes its maintenance more convenient. XC948U are comfortable in operation, fuel-efficient, reliable and durable.

PERFORMANCE AND FEATURES

Intelligent

The intelligent heat management system's large radiator + low-speed fan can automatically adjust the speed according to the heat dissipation requirements, so that the whole machine can quickly reach and maintain the best working condition, reduce energy consumption and reduce noise pollution. The fan has an automatic reversal function for self-cleaning in high dust environments.

Quantitative hydraulic system provides on-demand distribution of fuel supply during steering and work unit operation. At the same time, command-based control makes the operator's work easier and more fun.

B Automatic position restriction: Realize the position memory of the boom high position, low position and bucket recovery position, so that the working device automatically moves to the set position automatically.

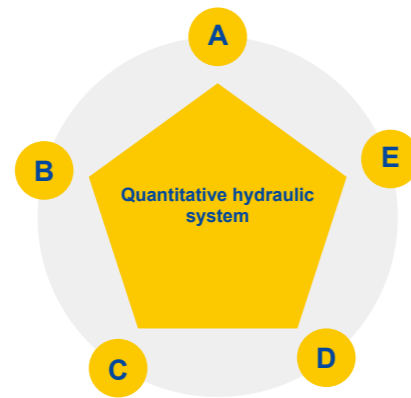

A Buffering function: When the boom is activated, stopped or close to the limit, the action buffer is decelerated to prevent impact and avoid severe vibration.

E Level and lift: Most machines have this function, like forklift. With this function, the machine may maintain its horizontal attitude when it completes its lifting and descending operation.

C Jog: Raise and lower the boom to achieve high precision jog control without affecting the maximum speed.

D Automatic leveling: automatic reset and leveling of the working device after unloading

HIGH SAFETY PERFORMANCE

Complying with standards of ISO 5006 operator vision field.

Complying with standards of ISO 3449, ISO 3471, ISO 3164 ROPS/FOPS cabs.

Complying with standard of ISO 2867, ISO 2860 ladders, passageway, operation platform and exit/ excess.

Flame retardant material applied in cab interiors, extinguisher equipped.

Complying with standards of ISO 10533, ISO 10570 lifting arm bracket and hinged lock devices.



COMFORT OPERATION

Spacious and ergonomic cab with excellent visibility.

FOPS/ROPS cab with heat and air conditioning provides good air flow through multiple vents.

The cab is well seated and insulated to provide a dust proof environment.

All switches are conveniently placed.

Digital gauges monitor the machine vital functions.

Suspension seat with lumbar support reduce operator fatigue.

Integrated F-N-R electronic lever of shifting function for precise control, easy operation and high working efficiency



EASY MAINTENANCE

Comfort Operation

Spacious and ergonomic cab with excellent visibility.

FOPS/ROPS cab with heat and air conditioning provides good air flow through multiple vents.

The cab is well seated and insulated to provide a dust proof environment.

All switches are conveniently placed.

Digital gauges monitor the machine vital functions.

Suspension seat with lumbar support reduce operator fatigue.

Integrated F-N-R electronic lever of shifting function for precise control, easy operation and high working efficiency



ENERGY SAVING

Load sense hydraulic system featuring automatic adjusting operation condition, improving fuel efficiency.

Intelligent independent cooling system, fan rotation on request for energy and noise reduction. Separated cooling layout with improved cooling efficiency and fuel efficiency.

Full automatic torque converter, two working mode, enabling the operator match the optimum efficiency according to working requirement.

Pilot control lever integrating F-N-R shifting function minimizing operation motions with higher working efficiency.

Improved traveling performance and load retention.

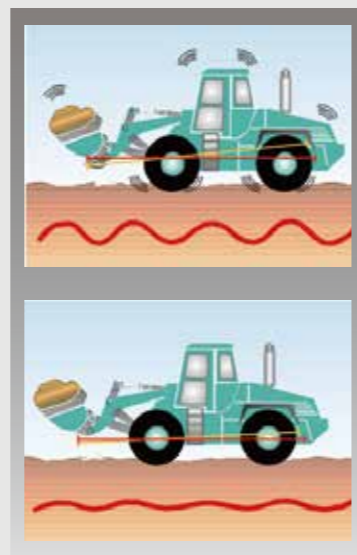

TECHNICAL SPECIFICATIONS

Item	Metric	U.S.
Rated Bucket	m ³	2.4
Rated load	Kg	4000
Operating weight	Kg	14500
Dumping height	mm	2810
Dumping distance	mm	1082
Wheel Base	mm	3050
Wheel track	mm	2020
Minimum ground clearance	mm	410
Length	mm	7882
height	mm	3405
Width	mm	2550
Dumping Angle	(°)	45
Maximum breakout force	kN	130
Maximum traction	kN	135
Tire center (turning radius)	mm	5200
Lifting time of boom	S	4.5
Total hydraulic cycle time	S	9.5
Tipping load (Maximum steering)	Kg	9000
Tipping load (Straight state)	Kg	11000
Engine Model	-	QSB6.7
Engine Rated Power	KW	142
Engine Rotate speed	r/min	2200
Speed F1/R1	Km/h	7/7
Speed F2/R2	Km/h	13/13
Speed F3/R3	Km/h	24/24
Speed F4	Km/h	38

OUTLINE DIMENSIONS

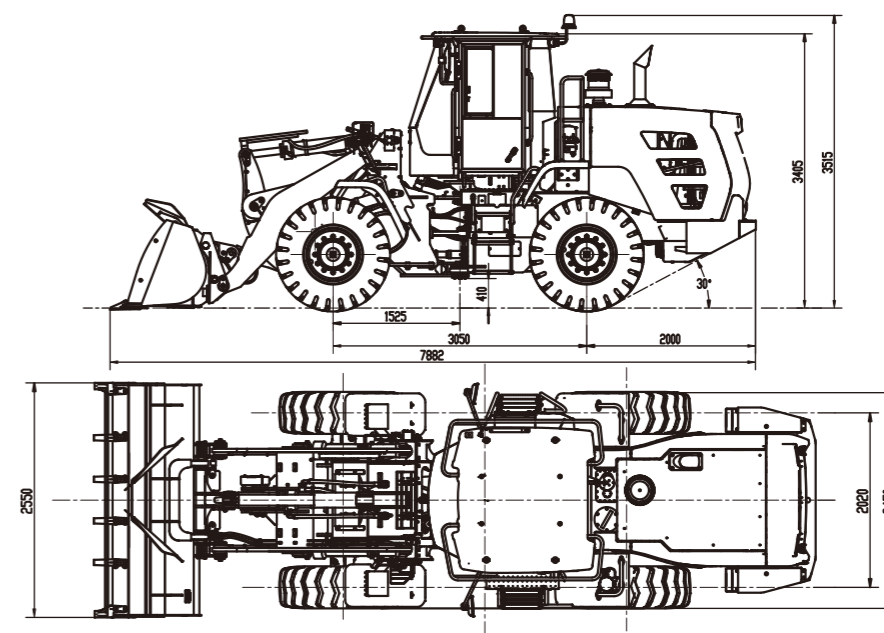

Optimum Services , XCMG Guaranteed



XCMG approved attachments



Genuine parts



Financial solutions



Maintenance contract



Telematics

Professional Integrated Complete Solutions

XCMG group has built a strong reputation based on the quality, reliability and durability of its construction machinery. What's more, XCMG has gradually established a service network to constantly provide its local integrated and highly efficient complete solutions for all customers.

Full Range of Services Ready for you

In order to respond to your needs as fast as possible, XCMG experts are on their way to your job site from one of our facilities near you. Full range of services are available in order to reduce your total cost of ownership and increase your revenue.



XCMG Global Spare parts System

