



TURBOFARMER COMPACTS TF33.7 - TF30.9

Merlo's factories in San Defendente di Cervasca (Cuneo) cover an area of 300,000 m² (with 220,000 m² indoor facilities)



1. Merlo SpA main offices
2. Final assembly lines
3. Lines for assembling components and cabs
4. Moulding of technopolymers
5. Automated storing and shipping centre
6. Machines plus attachments shipping centre
7. Final quality control
8. Technological centre
9. Steel and structural assembly lines centre
10. 3M attachments
11. CFRM (Training & Research Centre)

The Merlo Group

N° 1 for technology and safety

The Merlo brand has always been synonymous with advanced technology in the telehandler field and our history, since 1964, is hallmarked by experience based on determination and passion. The development of complex products, from the idea to the result, from design to sales, means being able to propose orientations for the most competitive markets. The outcome of our efforts are compact, easy to handle telehandlers ensuring incomparable operating performance, comfort, efficiency and safety. At Agritechnica 2013, three important awards were received that clearly demonstrate the technological and innovative superiority of our products:

- Turbofarmer 42.7 Hybrid: Gold Medal for innovation at Agritechnica.
- Turbofarmer II: Machine of the year 2014 in the "handling and logistics" category.
- Multifarmer: Selected as a "milestone" in agriculture.

The new modular Medium Duty and Compact Turbofarmer range was named «Machine of the Year» 2015 at Sima 2015 in the handling and logistics sector.

- Over 1.100 employees
- Surface area of 300,000 m² of which 220,000 m² are indoors
- 90% exports
- 600 dealers all over the world
- 8% of turnover invested in Research & Development
- 54 manufacturing robots



Automated boom bending workstation



Roto robotised welding of the chassis



Merlo presents
the Compact
range

Merlo Compact range

Maximum performance, minimum bulk

We were the first to launch a range of telehandlers dedicated to agriculture in 1996. Today, we proudly present the new Compact modular generation developed on the strength of experience acquired in 50 years of operations.

- Safety** ✓ FOPS-ROPS *also for the Low Profile version
- Comfort** ✓ **The largest cab in the category, standard on the entire range (even on the Low Profile versions)**
- Efficiency** ✓ **Maximum performance with reduced consumption (-18% diesel)**
- Performances** ✓ **2 engines: 75 HP Tier 4 Final and 115 HP Tier 4 Final**
 - 40 km/h** ✓ **Standard on the entire range!**
 - Fan Drive** ✓ **Available on the entire range. Radiators always clean!**
 - Hydraulic** ✓ **Gear pump, with electro-hydraulic joystick. Load Sensing pump with electronic joystick**



- **The largest cab in the category**
- **Lowered cab version without giving up anything. The same comfort!**
- **40 km/h as standard unique in its category**
- **EPD as standard -18% consumption**
- **Fan Drive for consistently efficient radiators**

* EN ISO 3449/2008, protection level II (highest protection level provided by the norm and equivalent to the fall of a 227 kg object from 5.22 metres)

Merlo Compact family

Flagship technology and performance



Comfort

- Largest cab on the market 1010 mm
- Standard cab on silent-block
- Cab version lowered to 2020 mm
- Reverse shuttle on Joystick, duplicated on steering column

Hydraulic system options

- Gear pump (G) and hydraulic command joystick
- Load-Sensing (LS) pump with electronic joystick and automatic accelerator

Efficiency – Powertrain

- Engines with 75 HP (Tier 4 Final) and 115 HP (Tier 4 Final) and Merlo 2-speed hydrostatic transmission
- EPD - Eco Power Drive as standard (EPD Top on 115 HP versions)

Innovative Merlo systems

- Tac-Lock rapid coupling of the attachments

Lifting capacity

- Booms from 7 to 9 metres
- Capacities ranging from 3 to 3.3 tons

Safety

- Cab compliant with FOPS/ROPS

Towing versatility

- Tow hook
- Hydraulic connections (2 opt.)
- Trailer braking (Hydr.)

Versatility in the field

- Approved for use as an agricultural tractor on the entire range
- Low Profile versions

The Compact range

A version for every requirement

		CAB									
		PROFILE		FINISHING		ENGINE		EPD		SAFETY	
MODEL		Steady	Low	STANDARD	PREMIUM	75 HP Tier 4 Final/Euro IIIB	115 HP Tier 4 Final/Euro IV	EPD	EPD TOP	CDC Light	CDC Display
TF33.7	TF 33.7 G	●	○	●	○	●					
	TF 33.7 - 115 G	●	○	●	○		●	●			
	TF 33.7 - 115	●	○	●	○		●		●	●	○
TF30.9	TF 30.9 G	●	○	●	○	●					
	TF 30.9 - 115 G	●	○	●	○		●	●			
	TF 30.9 - 115	●	○	●	○		●		●	●	○

● As standard. ○ On request.



Broad product offering:

- Available in 2 models and 6 different versions
- 2 boom lengths - 7 and 9 m
- 2 capacities - 3 and 3.3 tons
- 2 engines available - 75 HP Tier 4 Final/Euro IIIB and 115 HP Tier 4 Final/Euro IV



**Fan Drive available on the entire range.
Radiators always clean**

Engines & Transmissions

Higher performance and lower consumption

- ✓ The Turbofarmer range is equipped with two different engines: a Tier 4 Final 85 kW/115 HP 3.6 litres at 2300 rpm and a Tier 4 Final 55 kW/75 HP 2.9 litres at 2600 rpm
- ✓ Hydrostatic transmissions: two speeds and 40 km/h as maximum speed
- ✓ Merlo's hydrostatic transmissions have an oil circuit that is completely independent of the boom's oil circuit resulting in assuring maximum performance and longer oil's life
- ✓ Fan Drive **1** is a standard feature that allows you to change the rotation direction of the fan, from suction to blowing
- ✓ Models with 115 HP and G pump have Eco Power Drive (EPD); a standard feature that automatically controls the engine speed when driving, according to operating conditions.
- ✓ Models with 115 HP and LS pump have the EPD Top system, which adds Heavy Load Eco **2** and Speed Control **3** modes capabilities and the automated control of the diesel revs according to the movement of the joystick. The greater the inclination given to the joystick, the higher the rpm of the engine
- ✓ Speed control mode allows the forward speed of the machine to be memorized and to keep it constant (ideal for yard handling operations or road transport)
- ✓ The rpm selector **4** allows the operator either to set minimum engine speed to be kept (selector in position **A**) or to set a maximum engine speed while operating the joystick in proportional inclination mode (selector in position **B**)



- Tier 4 Final 55 kW/75 HP or 85 kW/115 HP engine
- 40 km/h unique in the category
- Fan Drive as standard to ensure the radiators are always clean
- EPD system (115 HP): consumption is reduced by 18% compared to traditional technologies
- EPD Top (LS models) guarantees boom responsiveness while keeping consumption to a minimum



4

Standard cab Largest cab in the category

1. Joystick with reverse shuttle (duplicated on steering wheel); ergonomic and easy to use.
2. Effective heating/cooling ventilation system.
3. Inching-Control: expanded sensitivity for creep movements.
4. Curved windscreen: maximum visibility and safety in work at height.
5. Merlo CDC Light.
6. Glovebox.

5

2

2

6

1

3

Cab with record comfort

One cab for two heights

The new evolved ergonomic cab with **unparalleled comfort with its 1010 mm in width** is standard on the Compact range.

The lowered version ("Low Profile"), 2020 mm, is available as an option. No space will be too low!

Cab height with standard cab and with lowered cab (Low Profile)

[Pressurized cab*]

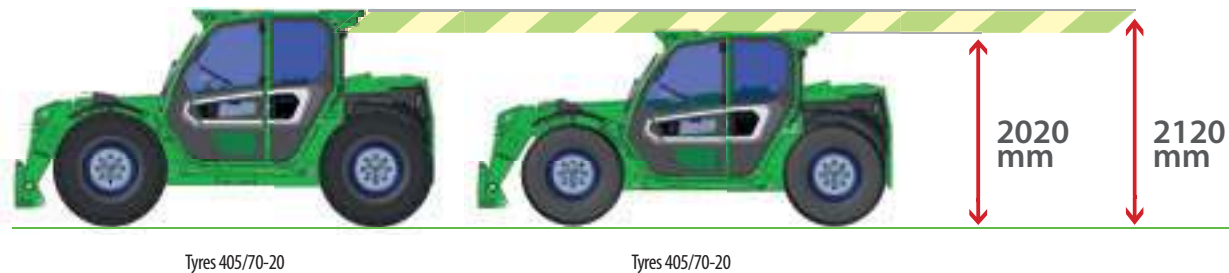

AIR FLOW VENTILATION SYSTEM



All the models are FOPS and ROPS approved, even in the "Low Profile" version.

New air-conditioning system. Warm-up and Cool-down times halved.

The new Merlo cab can now reach an internal temperature of 22°C with an external temperature of 43 °C and full sunlight and an internal temperature of 26°C with an external condition of -15 °C and no solar irradiation.

*According to the ISO 10263-3 standard, not approved for pesticides.

- 1010 mm wide. The cab is the largest in its category
- The same cab for two versions: standard 2120 mm height and low profile 2020 mm
- - 3 dB of interior noise; sound levels halved in comparison with the previous generation of machines



Premium cab

Feel like
in your car

The standard cab and the Premium cab are dimensionally identical and both compliant with the highest safety specifications ROPS and FOPS (level II). The Premium cab it is a perfect match for customers looking for automotive interior cab finishing. In fact it fits all uprights covered by finishing, new designed steering wheel and roof sun-blind. Air condition and five automatic ventilation flows selection are available as an optional in all models. Merlo CDC display, joystick type and EPD control type are features that enrich the product content of the Turbofarmer range and can be standard or optional depending on specific model configuration chosen. Moreover in the Premium cab the outside rear top spoiler (that eventually lodge the air conditioning system) matches colorwise Merlo's green. Please ask your local dealer for more details.

CDC - Merlo's Dynamic Load Control

Maximum versatility on LS models



The Merlo Group considers safety as an absolutely essential value, all Merlo models meet the most strict regulation. LS models are featured by the M CDC system to allow every operator to work in total safety by fully exploiting the potential of the telehandler and the equipment used. The operator can check at any time the dynamic stability of the vehicle, thanks to the dot **3** on the screen in the M CDC Display (optional) or the traffic light on the front upright in the M CDC Light version.

For manoeuvres that may give rise to a telehandler stability risk, the M CDC system will block the boom and prevent any further movements that may worsen the situation.



The traffic light indicator on the right side pillar provides a fast and clear information about the machine's stability.



CDC Display*

All the safety information is clearly shown in the colour awesome 8.5" display. An indicator on the load chart informs the operator about the dynamic stability of the telehandler and the M CDC avoids risks for the longitudinal equilibrium of the balance by blocking boom movement if needed.

- | | |
|---|--------------------------------|
| 1. Equipment in use | 4. Load detection menu |
| 2. Boon work area | 5. Operating parameters |
| 3. Current boom-load positioning
(represented with a colored dot) | 6. Work information |
| | 7. Stability index |

* A Merlo unique feature available as an option in LS models.

Compacts, excellent
ground clearance

340 mm
ground
clearance.
405/70-20
tyres



Merlo planetary axles

Designed for maximum performance and long duration

Our Compact telehandlers are equipped with a new generation of planetary axles that have been conceived, designed and constructed in-house.

The solution with planetary reducers was chosen to keep the machine's height as high as possible. The axles consist of a central cast iron body, planetary reducers and differential locking. Braking is ensured by 4 dry disc brakes keyed onto the axle shafts, allowing a remarkable reduction in friction and, consequently, consumption.

To complete the specifications offered, the Compacts telehandlers are equipped with a parking disc brake which is automatically engaged when the diesel engine is switched off, or engaged directly by the operator in the event of work on sloping surfaces.

The new axles ensure an excellent ground clearance of 340 mm (405/70-20 tyres), making it possible to pass obstacles with agility.



THREE STEERING MODES



FRONT WHEEL STEERING MODE



FOUR WHEEL STEERING



CRAB STEERING



The manual parking brake selector is automatically engaged when the engine is switched off.

- Axles conceived, designed and produced in-house by Merlo
- Compact solution to maintain a reduced height in all the versions
- 340 mm ground clearance
- Three steering modes
- Dry brakes to reduce friction and consumption while ensuring 40 km/h
- Automatic engaging of the parking brake when the engine is switched off



Boom handling: speed and precision

Merlo precision and technology

An effective and cutting-edge boom

Merlo produces the booms mounted on its telehandlers in-house and has developed unique technologies to make them strong yet lightweight, protect handling mechanisms against accidental blows and allow users to position the load in the most precise manner possible.

- ✓ Boom sheet metal welded on the boom's neutral bending axis
- ✓ Cartridge protected handling system inside the boom, thanks to a patented solution that is easy to access if maintenance is needed
- ✓ Tac-Lock: hydraulic attachment clamping system from the cab



Tac-Lock: hydraulic attachment clamping system from the cab



Pipes, power cables and auxiliary hydraulic are all located inside the boom

- Lighter but stronger booms: robotised welding on the neutral axis, area with less strain
- Extension mechanism well-protected inside the boom
- Carriage equipped with Tac-Lock hydraulic locking

Merlo attachments,
many solutions in a single handler



Developing multi-purpose solutions

More efficiency and productivity thanks to Merlo design

Merlo adopts simple and effective guidelines in the evolution of its products.

From conception to development, everything is studied, designed and created in the Group's research centre. This simple "rule" also applies to attachments.

Backed by years of experience, Merlo's engineers have developed a wide range of attachments, divided by type and load capacity.

This way of working makes possible to offer a wide portfolio of well tested and interchangeable equipment that save time and fatigue.

BALE FORKS



MANURE FORK WITH CLAW

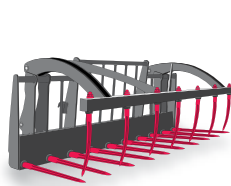

GRIPPERS FOR BALES

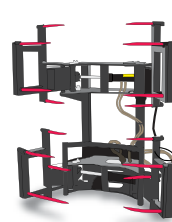

MULTI-PURPOSE LOADER WITH CLAW

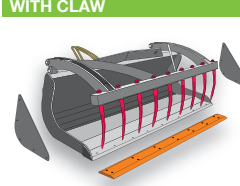

LOADERS

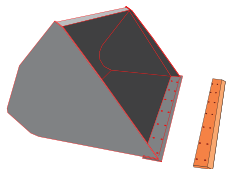

HOOKS/LIFTING BOOMS



GRIPPERS FOR WRAPPED BALES

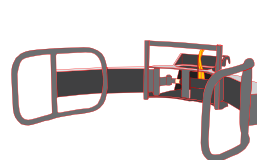

PLATFORMS

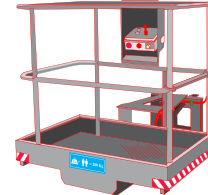

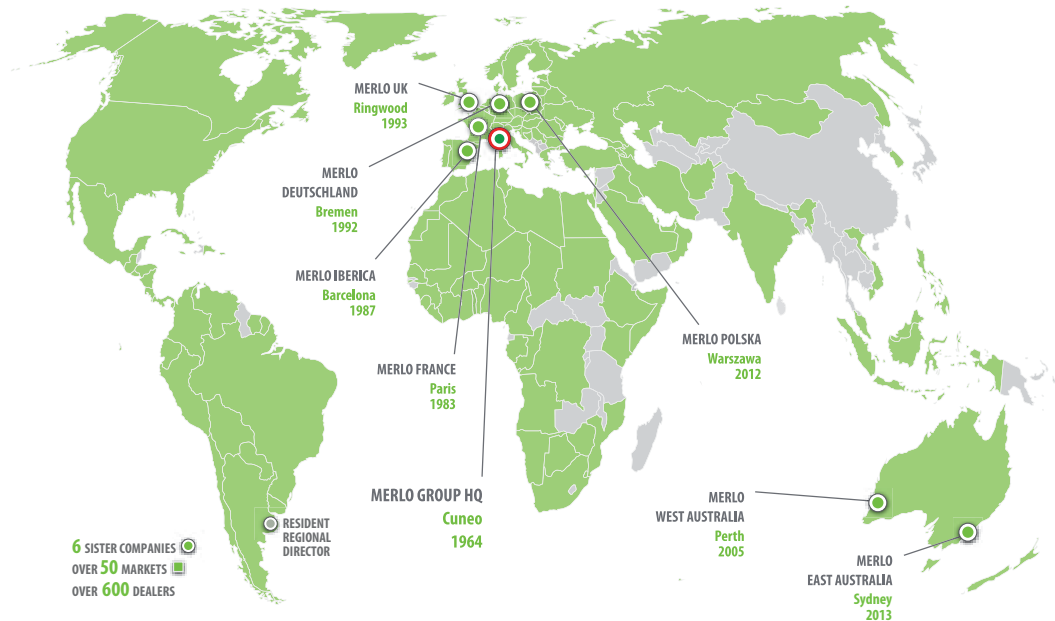

TRAINING CENTRE

The Merlo Training and Research Centre (CFRM) has made safety training and instruction in the use of the machine its mission. The CFRM provides training courses for operators of person-carrying overhead platforms, forklift trucks, telehandlers, cranes, earth-moving machinery, agricultural and forestry tractors, snow ploughs and urban cleaning vehicles.



Countries where Merlo is a market leader



MOVIMATICA MERLO INFOMOBILITY

Is the new system, conceived and built within the Merlo Group, for managing vehicles remotely: it enables GPS radio-localisation in real time, monitoring operation and use, receive and manage malfunction or burglar alarms and also send commands for handling events via the internet.



THE MERLO WORLD

In a globalised world, **the customer always comes first!**

From excellent products to excellent service. In 2008, Merlo has adapted its production process to meet the needs of the ISO 9001 quality control system. The process is perfected and improved continuously.

At the same time, the foundations have been laid to put the Customer first, implementing investments aimed at Services such as Financing, Aftersales training, Spare parts and Telematic Means such as remote diagnostics, thanks to the Merlo Mobility project.

Automatic spare parts warehouse	2011	2014
Storage volume	1000 m ³	10.000 m ³
Filling	100%	85%
Percentage of codes managed	50%	86%
Percentage of order lines managed	65%	94%
Pick-up time	90"	30"
Number of codes	8.000	17.000

NEW PARTS CENTRE

The new spare parts warehouse covers an area of 7,000 m², with storage capacity for of 10,000 m³ for a total of 20,000 different codes. Furthermore, it can automatically manage 94% of the order lines that are processed daily, with an average withdrawal time of 30" per line.

The first fill per order line is over 99% with delivery times for urgent orders within 24 hours.



Order processing and shipment area

TECHNICAL INFORMATION	TF 33.7 G	TF 33.7 - 115 G	TF 33.7 - 115	TF 30.9 G	TF 30.9 - 115 G	TF 30.9 - 115
Total unladen mass, without forks (kg)	6500	6500	6500	6700	6700	6700
Maximum capacity (kg)	3300	3300	3300	3000	3000	3000
Lifting height (m)	6,6	6,6	6,6	8,6	8,6	8,6
Maximum reach (m)	3,5	3,5	3,5	5,7	5,7	5,7
Maximum operating height (m)	5,7	5,7	5,7	5,8	5,8	5,8
Maximum operating reach (m)	1,4	1,4	1,4	1,7	1,7	1,7
Capacity at maximum height (kg)	2600	2600	2600	1200	1200	1200
Capacity at maximum reach (kg)	1350	1350	1350	600	600	600
Turbo motor (displacement/cylinders)	2,9/4	3,6/4	3,6/4	2,9/4	3,6/4	3,6/4
Tier 4 Interim motor power (kW/HP)	55/75	85/115	85/115	55/75	85/115	85/115
Maximum speed (km/h)	40	40	40	40	40	40
BSS - Hydro-pneumatic boom suspension	○	○	○	○	○	○
Fuel tank (l)	85	85	85	85	85	85
G - Hydraulic gear pump (bar-l/min)	210/98	210/98	-	210/98	210/98	-
LS - Hydraulic Load-Sensing pump (bar-l/min)	-	-	210/125	-	-	210/125
Fan Drive Pump (l/min)	36	46	46	36	46	46
Flow Sharing Distributor	-	-	●	-	-	●
Hydraulic oil tank (l)	85	85	85	85	85	85
FOPS (ISO 3449) and ROPS (ISO 3471) cab	●	●	●	●	●	●
Electrohydraulic joystick	●	●	-	●	●	-
Electronic joystick	-	-	●	-	-	●
Hydrostatic transmission	●	●	●	●	●	●
Differential lock (A-P)	○	○	○	○	○	○
Dual Control Reverse Shuttle (joystick/steering wheel)	●	●	●	●	●	●
Inching Control progress control from pedal	●	●	●	●	●	●
Permanent four-wheel drive	●	●	●	●	●	●
Four-wheel steering	●	●	●	●	●	●
Automatic parking brake (when the engine switches off)	●	●	●	●	●	●
Work headlights on cab (2 A + 2 P)	○	○	●	○	○	●
LED work headlights on cab	○	○	○	○	○	○
Change of speed	2 speeds	2 speeds	2 speeds	2 speeds	2 speeds	2 speeds
EPD - Eco Power Drive	-	Standard	TOP	-	Standard	TOP
Dynamic Load Control M CDC LIGHT*	-	-	●	-	-	●
Standard tyres	405/70 20	405/70 20	405/70 20	405/70 20	405/70 20	405/70 20
Type approval as an agricultural tractor	○	○	○	○	○	○

*Merlo CDC Display and Premium cab available as an option.

● As standard. ○ On request.

TF 33.7 WITH FORKS

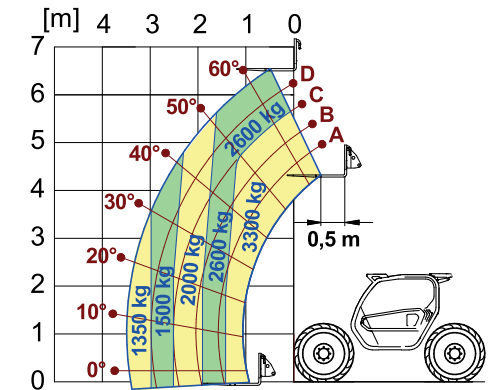

EN 1459/B

TF 30.9 WITH FORKS

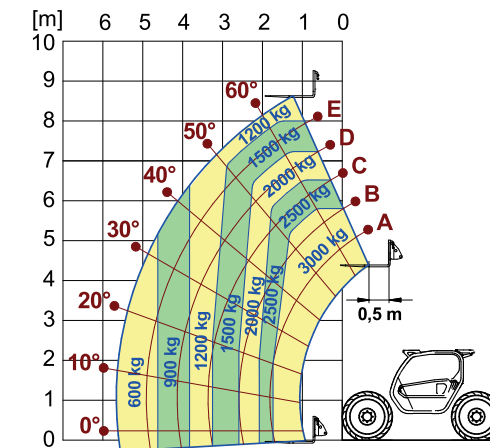

EN 1459/B

TECHNICAL INFORMATION

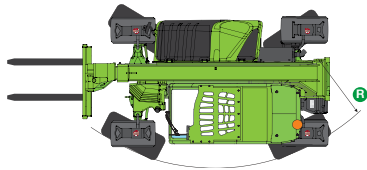
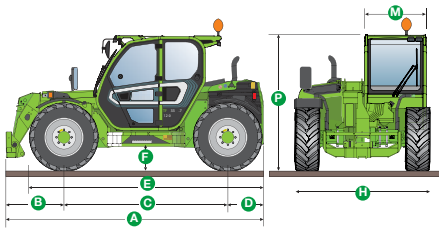

DIMENSIONS TURBOFARMER COMPACTS

A (mm)	4315
B (mm)	990
C (mm)	2740
D (mm)	585
E (mm)	3910
F (mm)	340
H (mm)	2100
M (mm)	1010
P (mm)	2120/2020*
R (mm)	3930

*version with standard cab and Low Profile

New Compact modular models The advantages that make the difference

- ✓ 6 models with low cab. A complete offer for poultry farming and more!
- ✓ Pressurised cab as standard*
- ✓ Fan reverse shuttle as standard, for radiators that are always clean to ensure maximum efficiency

From now on, you don't have to give up anything

- ✓ 40 km/h approval for agricultural tractor use, also on Low Profile versions
- ✓ The same comfort (standard and Low Profile versions)
- ✓ Even greater accessibility to the Low Profile cab

* Cab not approved for pesticides.

OVER 50 YEARS OF CONSTANT COMMITMENT TO WORKING TOGETHER WITH YOU

- 1964** - Establishment of the Merlo Group
- 1966** - DM and DBM: the first dumper and the first self-loading concrete mixer
- 1981** - SM: the world's first telescopic handler
- 1987** - Panoramic: the world's first telehandler with side engine
- 1991** - Roto: the world's first telehandler with rotating turret
- 1996** - Turbofarmer: the first telehandler in Europe type-approved as an agricultural tractor
- 1998** - P20.6: the ultra-compact telehandlers
- 2000** - Multifarmer: the first agricultural tractor with telescopic boom
- 2001** - MM: the first forestry attachment-carrier
- 2010** - Hybrid: the first diesel/electric hybrid telehandler
- 2012** - Modular: a new concept of telescopic handler
- 2013** - Three important awards at the Agritechnica in Hanover:
 - Hybrid 42.7: gold medal for technological innovation
 - Turbofarmer II range: "machine of the year 2014"
 - Multifarmer 40.9: "a milestone in agricultural machinery"
- 2015** - New modular Medium Duty and Compact Turbofarmer named "machine of the year" 2015 at Sima in Paris



MERLO S.P.A.

Via Nazionale, 9 - 12010 S. Defendente di Cervasca - Cuneo - Italia

Tel. +39 0171 614111 - Fax +39 0171 684101

www.merlo.com - info@merlo.com

The Telehandlers outlined in this documentation can be equipped with optional or special accessories that are not included in standard equipment but only on request.

In certain countries, not all models or attachments may be available because of market or regulatory restrictions.

Technical data and information are up-to-date at the time of printing this documentation. Merlo reserves the right to make modifications arising from natural technological evolution without any obligation on its part.

Your trusted Merlo Dealer will be delighted to provide you with all updates concerning our products and services.