

# Concrete Mixer

DBM 2500 - DBM 3500





- Not Available  
 ● Standard  
 ○ Optional

PERFORMANCE AND FEATURES	DBM 2500	DBM 3500	
	Factory order only	Factory order only	
<b>Performance</b>			
Unladen weight (kg)	7050	7400	
Concrete yield capacity (l)	2500	3500	
Drum volume (l)	3500	5000	
Loading bucket volume (l)	700	700	
Water pump capacity (l/min)	250	250	
Water tank capacity (l)	930	930	
Maximum unloading height without discharge chute (mm)	1760	2060	
Drum rotation speed (tr/min)	0 ÷ 26	0 ÷ 18	
<b>PowerTrain</b>			
Engine	DEUTZ TCD3.6	DEUTZ TCD3.6	
Engine power (kW/HP)	74.4/100	74.4/100	
Anti-pollution technology	TIER 4F+DOC	TIER 4F+DOC	
Fuel tank capacity (l)	200	200	
AdBlue tank capacity (l)	18	18	
Axles	Drop portal	Drop portal	
Brakes	Automatic parking brake		
Maximum gradeability: Fully laden (%)	45	40	
Maximum gradeability: Empty (%)	55	50	
Maximum transversal slope (%)	15	15	
Maximum speed (km/h)	40	40	
<b>Configuration</b>			
ROPS Cab	●	●	
Pedal Inching-Control	●	●	
Hydrostatic transmission	●	●	
Permanent four-wheel drive	●	●	
All wheel steering	●	●	
Three steering way	●	●	
Standard tyres	405/70-20	500/45-20	

## Dimensions



	DBM 2500	DBM 3500
A (mm)	6220	6480
B (mm)	1760	2060
C (mm)	2750	2750
D (mm)	5250	5460
E (mm)	1350	1350
F (mm)	470	435
F1 (mm)	470	435
H (mm)	2300	2355
L (mm)	2300	2300
O (mm)	2805	2770
O1 (mm)	2975	2940
N (mm)	3720	3880
P (mm)	2900	3100
R (mm)	4165	4200
S (mm)	4400	4730
T (mm)	3590	3590
V (mm)	1620	1620

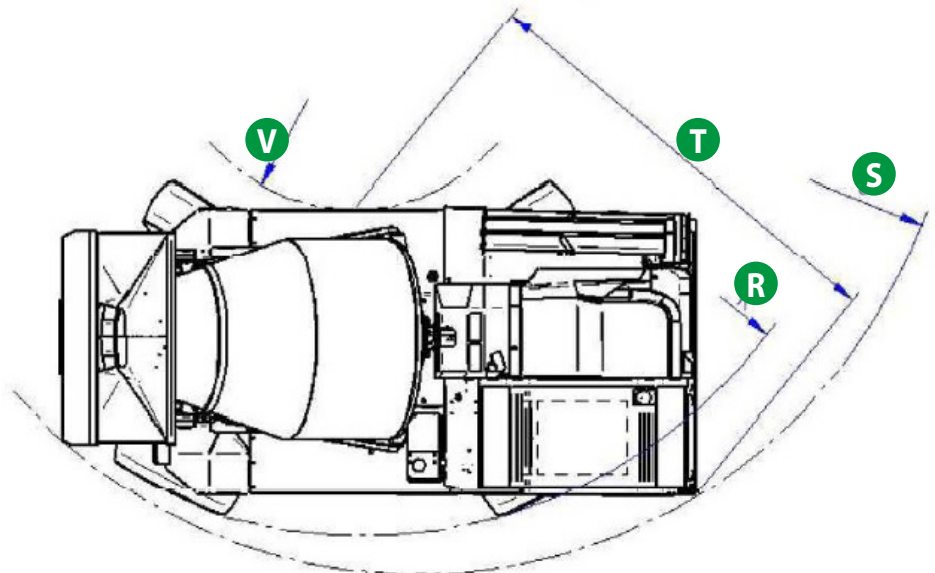
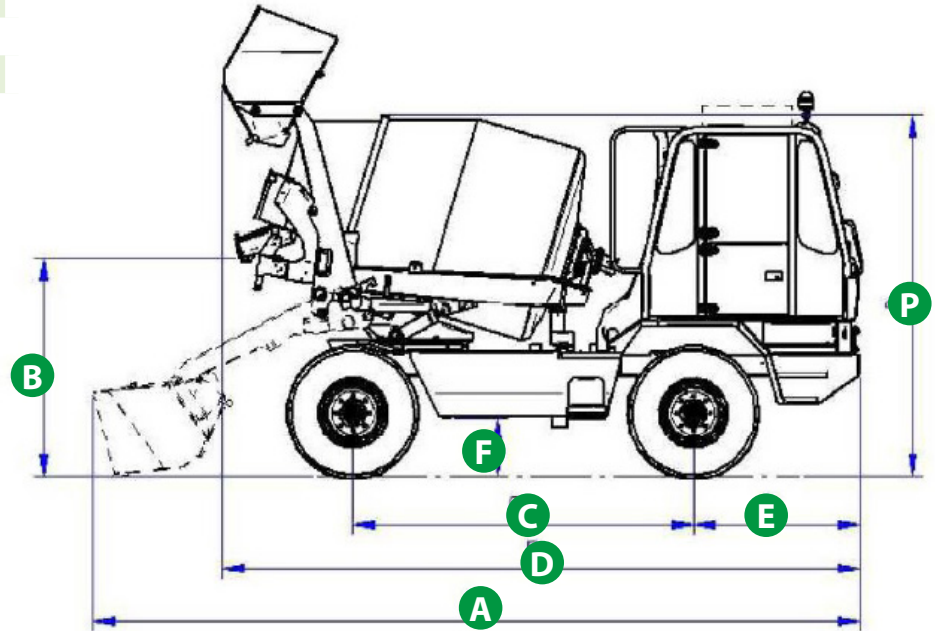
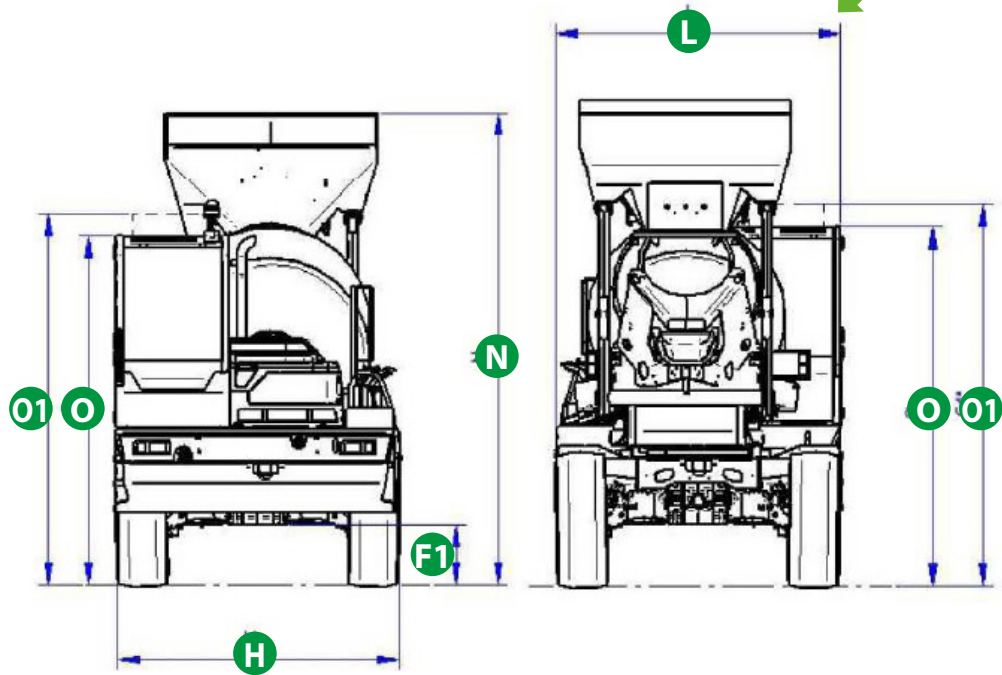



**DBM2500:**

\_\_\_ - VIN: \_\_\_ - SAV: \_\_\_ - \_\_\_

**DBM3500:**

\_\_\_ - VIN: \_\_\_ - SAV: \_\_\_ - \_\_\_

**MERLO GROUP AUSTRALIA PTY LTD**

27 Colin Jamieson Dve, Welshpool (Perth), WA 6106

Tel. (08) 9358 3110 - Fax (08) 9358 4110

120 Toongabbie Road, Girraween, NSW 2145

Tel. (02) 9688 0600

Tel:1300 657 325

[info@merloaustralia.com.au](mailto:info@merloaustralia.com.au)

[www.merlo.com](http://www.merlo.com)



Your Merlo dealer

